

RB24 Relay Box
for 24 VDC motors
part # 40995J



Applications

- A Relay Box acts as an interface between FFI DC actuators and Direct Digital Control (DDC) systems such as Building Automation Systems (BAS), Heating/Ventilation/Air Conditioning Systems (HVAC) or Home Automation Systems.
- Not UL recognized; not recommended for commercial/institutional projects.
- Use with Momentary Contact SPDT Switch, FFI part #SW5657-2W.

Features

- A Control Relay Box allows independent control (open/close switching) of low voltage actuators connected to it.
- A Control Relay Box does not supply power; it receives power from an external, low voltage power supply.
- Dry contact connection by single pole single throw momentary switch and/or external control system.
- Controls multiple actuators with maximum current draw of 20 amps @ 24 VDC.
- FFI recommends do not exceed 80% of maximum capacity for relay boxes, therefore 16 amps.
- Two-year UCS manufacturer's warranty. Requires reading FFI Installation Guide for applicable products before purchase, and confirmation of project and installation specs by licensed electrical contractor.

Control Relay Box RB24 Specifications

Power Input	24 VDC ± 10%
Power Output ("Motor Group 1")	10 amps @ 24 VDC*
Power Output ("Motor Group 2")	10 amps @ 24 VDC*
Number of Output Leads	2 wires (polarity inversion)
Safety Mark	CE; not UL Recognized/labeled
Operating Environment	14° to 140° F (-10° to 60° C)
Max. Relative Humidity	60%
Case Dimensions	154 x 113 x 75 mm (6" x 4.5" x 3")

* Do not exceed 80% of maximum capacity, therefore 8 amps each group.

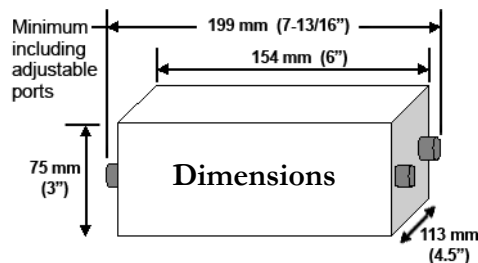

Recommendations for FFI Actuators & Controls: FFI only recommends UL compliant systems. FFI is a UL registered firm. Read FFI data sheets & installation guides before specifying project details. Project-specific needs vary depending on the number of actuators, electrical layouts, building management systems, distance between power supplies & actuators, and other details. Project specifications to comply with electric & building codes—for wire gauge, wire connections and run distance, conduits, junction boxes—must be arranged by the project electrical contractors. Distribute this guide to all project parties, including electrical contractors, architects, and building management personnel.

Control Relay Box RB24 for 24 VDC motors only - Internal Connections

CONNECTION SPECIFICATIONS SHOWN ARE GENERIC AND NOT PROJECT SPECIFIC

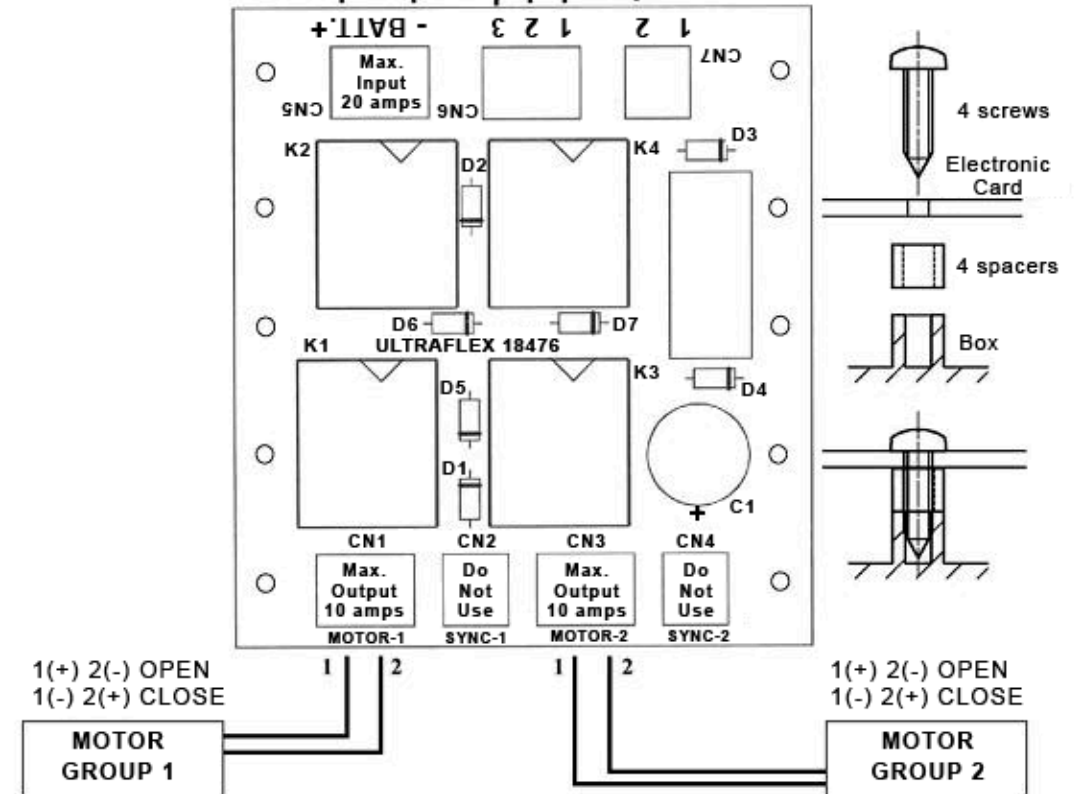
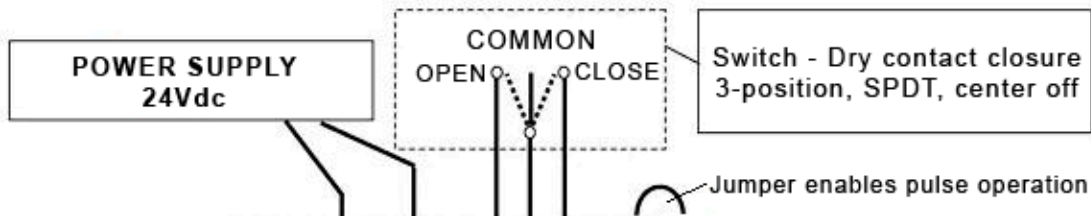
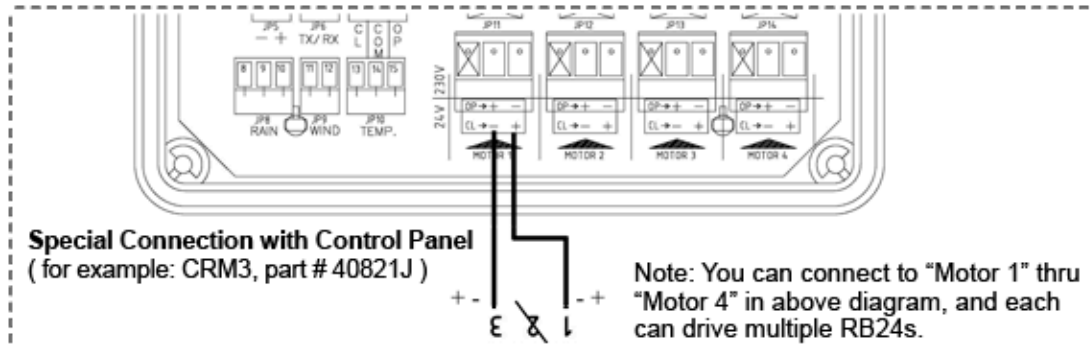

Jumper IN: Press switch once and release. To stop motor, press opposite command.
Jumper OUT: Press and hold switch until window moves to desired position.

Also read FFI actuator data sheets and installation guides before specifying and purchasing products for automation projects.